

# The **isocheck** Batten System (for concrete floors)

## LAYING & FIXING INSTRUCTIONS

### SITE CONDITIONS

Before installation of **isocheck** Batten it is essential that all site conditions are as specified. Installation should not commence until these conditions are met.

#### Sub Floor

Concrete sub-floor is to be swept free of any loose debris leaving a smooth surface on which to place the **isocheck** Batten. The building must be weatherproofed and wet trades dried out before commencing installation of the flooring system. All joints and air paths between concrete units and at perimeter walls must be grouted. Components exposed to wet conditions such as ingress of rain or plumbing leaks should be discarded and replaced. The concrete sub floor must be level and smooth.

#### Services

The location of services should be detailed at an early stage. Services should be kept at least 150mm away from walls to allow space for perimeter bearers.

#### Ceramic Tiles

Good detailing and the use of modern flexible adhesives can significantly reduce risks. When laying ceramic tiles on floating floors please contact us for specialist advice.

#### Storage

All components should be kept inside, under cover and in dry conditions at all times. Materials should be located in the area in which they are to be fixed at least 24 hours prior to fixing. Do not place large quantities of material such as chipboard or plasterboard on top of laid flooring as this extreme loading can damage the resilient layers.

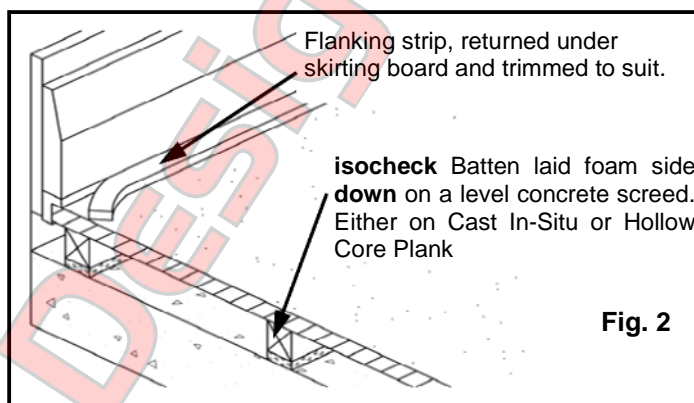
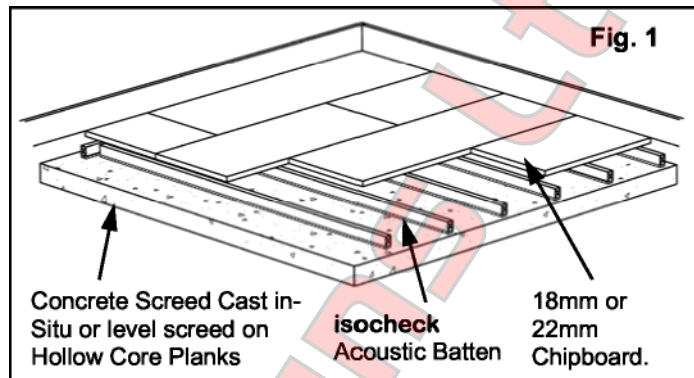

### INSTALLATION PROCEDURES

Lay **isocheck** battens around the perimeter of the room foam side down approximately 50mm from the wall. **isocheck** Battens should be laid at 400mm centres for 18mm chipboard, or 500mm centres for 22mm chipboard under normal domestic loading.

Having laid perimeter battens infill the remaining area with battens as above. When laying alternate rows of **isocheck** Battens, commence with a half-length so that the ends of bearers are staggered. Leave a small gap between batten ends. Where services run across bearers – do not notch. Cut the batten either side of the pipe leaving a 10mm gap. At each threshold a mesh of batten should be placed across each doorway to provide extra support.

Lay chipboard sheets with long edges across the **isocheck** battens leaving a 10 mm gap at the perimeter. The sheets in adjacent rows must be staggered in a stretcher-bonded fashion. If short edges overhang a batten an additional batten must support them.

Annular ring or ring shank nails and P.V.A adhesive should be used for fastening the chipboard to **isocheck** battens. The nails must be long enough to securely fix the chipboard but not so long as to bridge the foam on the underside of the bearer. Adhesive should be applied to the batten prior to laying each sheet of chipboard.

All tongue and grooved joints must be continuously glued with adhesive both on the top of the tongue and the bottom of the groove otherwise any movement will lead to squeaking. Spot gluing is NOT sufficient (to prevent squeaking). All joints must be tightly butted and excess glue removed with a damp cloth. Finally the boards should be surface nailed / screwed with a minimum of four nails or screws across the width of each sheet, two about 25mm from each end and two equidistant between. Ensure that gaps where services come through the flooring are sealed with acoustic sealant to prevent airborne sound leakage.



# The **isocheck** Batten System (for concrete floors)

## LAYING & FIXING INSTRUCTIONS continued

### DESIGN RECOMMENDATIONS

Partitions should normally be erected from the sub-floor and not on top of the floating floor. Where lightweight timber or metal stud non load bearing partitions are built from the top of the floating floor a double row of battens should be placed beneath the partitions. All inspection panels should be square and supported along all edges by **isocheck** battens. Access panels should be screwed down.

In areas where heavy loadings are anticipated, such as kitchens and bathrooms, the bearer centre's should be reduced to between 200 & 300mm. In cases of extraordinary, loading advice should be sought from the specifier or manufacturer. Custom Audio Designs Technical Department are available to provide advice where required. The need for intermediate expansion gaps between sheets of chipboard must be considered where there are uninterrupted runs of flooring more than 5 metres in length. Expansion provision should be calculated at a rate of 2mm per metre run and the gap filled with acoustic sealant.

Position the flanking strip in the perimeter gap adjacent to the perimeter wall. The preformed 'L' shape will prevent it from falling down the gap. Fix the skirting board, lightly trapping the strip between the bottom of the skirting board and the flooring. Remove any excess flanking strip with a sharp knife. It is essential to isolate the skirting from the floor to prevent impact sound flanking transmission.

### ADDITIONAL SUPPORT

Where the edge of the flooring boards fall between a line of battens, or where there are concentrated loads such as baths, additional sections of batten are required. For joints in the boards place a section of acoustic batten under the joint to support adjacent floorboards and fix as normal.

### PROTECTION

It is advisable to protect the floor surface from any damage by following trades during the remainder of the construction period.

## Health and Safety

### HANDLING

Acoustic Batten can be awkward to lift. Observe proper lifting methods and if transporting around site, by hand. Care should also be taken to protect hands from splinters during manual handling.

### CUTTING

The cutting of Acoustic Batten, either by hand or machine, will produce dust that may be an irritant if inhaled. Use dust masks when carrying out any cutting operations.

### STORAGE

The foam resilient layer, on Acoustic Batten is manufactured using polyethylene polymers. Therefore, Acoustic Batten should be stored in safe dry areas, laid horizontally and kept away from naked flames. **NO SMOKING** policies must be strictly enforced.

### DISPOSAL OF WASTE

In accordance with the Environmental Protection Act 1990 a licensed waste disposal contractor should dispose of any waste. Preserved wood may be disposed of in landfills or burned in commercial and industrial incinerators or boilers in accordance with National and Regional regulations.

